

A. Delestadius,

Shackle.

N^o 33,917.

Patented Dec. 10, 1861.

Fig. 1.

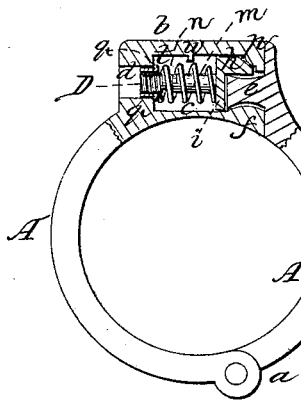

Fig. 2.

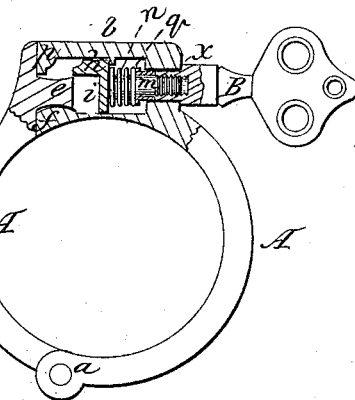

Fig. 3.

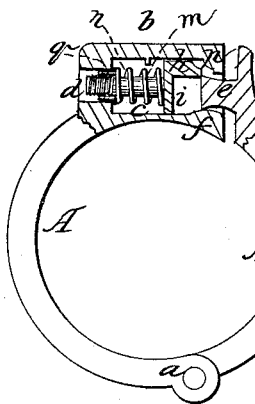
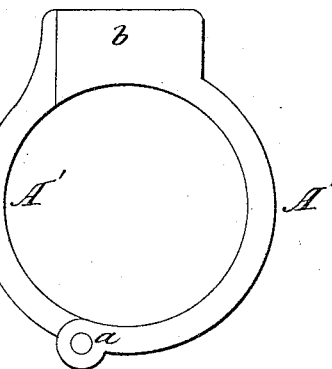

Fig. 4.



Witnesses:

Charles C. Foster

Charles Howson

Inventor.

Henry Howson

Atty for A. Delestadius

UNITED STATES PATENT OFFICE.

ALFRED DELESTATIUS, OF PHILADELPHIA, PENNSYLVANIA, ASSIGNOR TO
ANDREW RANKIN, OF SAME PLACE.

IMPROVEMENT IN MANACLES.

Specification forming part of Letters Patent No. 33,917, dated December 10, 1861.

To all whom it may concern:

Be it known that I, ALFRED DELESTATIUS, of Philadelphia, Pennsylvania, have invented certain new and useful Improvements in Manacles; and I do hereby declare the following to be a full, clear, and exact description of the same, reference being had to the accompanying drawings, and to the letters of reference marked thereon.

My invention relates to improvements in manacles and shackles used in securing prisoners, and my improvements, which are fully described hereinafter, are such as to render the unlocking of the manacles or shackles by prisoners a matter of much greater difficulty than is experienced in picking the locks of or otherwise opening those of ordinary construction.

In order to enable others to make and use my invention, I will now proceed to describe its construction and operation.

On reference to the accompanying drawings, which form a part of this specification, Figure 1 is a front view, partly in section, of one of the jointed rings of my improved manacles, showing the two portions of the rings locked together; Fig. 2, the same, showing the ring unlocked; Fig. 3, the same, showing the two portions of the ring as in the act of being locked together; and Fig. 4 an exterior view of one of the jointed rings.

Similar letters refer to similar parts throughout the several views.

Each ring of my improved manacle is composed of the two curved pieces of metal A and A', jointed together at *a*, the portion A having an enlargement *b*, in which is a chamber *c*, containing the bolt D. In this enlargement are two openings communicating with the chamber *c*, one opening *d* being for the admission of the key B, Fig. 2, the other being for the reception of the projection *e* of the portion A' of the ring. The under side of this projection is concave, as seen in the drawings, and (when the two portions of the rings are locked together) fits over the rounded projection *f* formed at the entrance of the opening which receives the projection *e*. The head *i* of the bolt D fits snugly, but so as to slide freely in the chamber *c*, and on this head is a projection *h*, the under side of

which fits against the top of the projection *e* of the portion A' of the ring, and is arranged to bear against the projection *p*, the latter limiting the movement of the bolt *n* in one direction and the lip *w* limiting its movement in the opposite direction. On the end of the stem *m* of the bolt is formed a screw adapted to the internal screw formed in the end of the key B, the stem *m* being surrounded by a coiled spring *n*, one end of which bears against the head *i* of the bolt, the opposite end bearing against a ferrule *q*, the exterior of which fits snugly, but so as to move freely in the opening *d*, the interior admitting freely the screwed end of the bolt. The ferrule is provided with a flange *t*, which is pressed by the spring *n* against the inside of the chamber *c*, the same spring tending to maintain the projection *h* of the head *i* of the bolt in contact with the projection *p*.

On inserting the stem of the key into the opening *d* and screwing it onto the end of the bolt D, the key, bearing with its shoulder *x* against the projection *b*, will draw the bolt to the position shown in Fig. 2, the projection *h* of the head of the bolt being moved away from the projection *e* of the portion A' of the ring. In pulling the two portions of the ring apart, which requires a slight exertion, they will yield sufficiently to allow the projection *e* to pass over the rounded projection *f*, after which the ring is unlocked. On withdrawing the key the bolt, through the action of the spring *n*, will recover its former position. The ring is locked by simply forcing the projection *e* into the entrance to the chamber *c*, in doing which the upper corner of the projection *e* will bear against the end of the projection *h* of the bolt and force the latter back, the portion A of the ring again yielding, so that the lower corner of its projection *e* may slide over the rounded projection *f*. When the said projection *e*, however, has reached its destination, the bolt will recover its former position, (seen in Fig. 1,) the projection *h* fitting over the projection *e* and effectually preventing the unlocking of the ring without the aid of the key.

It will be observed that the ring is partly self-fastening without the aid of the bolt, the two parts of the rings themselves serving as

springs to yield as the projection *e* is passing over the projection *f* and to recoil as soon as the projection reaches its destination, the two parts of the ring again yielding, when the projection *e* is withdrawn from the entrance to the chamber *c*. The projection *h* of the bolt, however, when above the projection *e* effectually prevents a sufficient yielding of the two parts of the spring to allow the projection *e* to pass over the rounded projection *f* and from the entrance to the chamber *c*.

Although I have alluded to my improvements as relating to manacles only, they are equally applicable to shackles for the ankles.

It is well known that the locks of ordinary manacles and shackles are readily picked by the most simple instruments for raising or withdrawing the bolt or catch, and even by a blow imparted to a particular point of the rings.

Owing to the presence of the ferrule *q*, the difficulty of gaining access to the bolt *D* so as to draw it back will be evident. It will be also evident that no blow imparted to the ring can withdraw the projection *e* from its entrance to the chamber *c*.

I claim as my invention and desire to secure by Letters Patent—

1. The portion *A* of the ring, with its rounded projection *f*, in combination with the portion *A'* of the ring and its projection *e*, the whole being constructed and arranged, substantially as set forth, so that on closing or opening the ring the two parts will yield slightly and allow the projection *e* to pass over the projection *f*.

2. The spring-bolt *D*, constructed and arranged within the chamber *c* in relation to the projection *e*, substantially as and for the purpose herein set forth.

3. The ferrule *q* and its flange *t*, arranged in respect to the chamber *c*, the entrance *d* to the same, the stem of the bolt *D*, and the spring *n*, substantially as described, for the purpose specified.

In testimony whereof I have signed my name to this specification in the presence of two subscribing witnesses.

ALFRED DELESTATIUS.

Witnesses:

HENRY HOWSON,
JOHN WHITE.